

# UPS RANGE

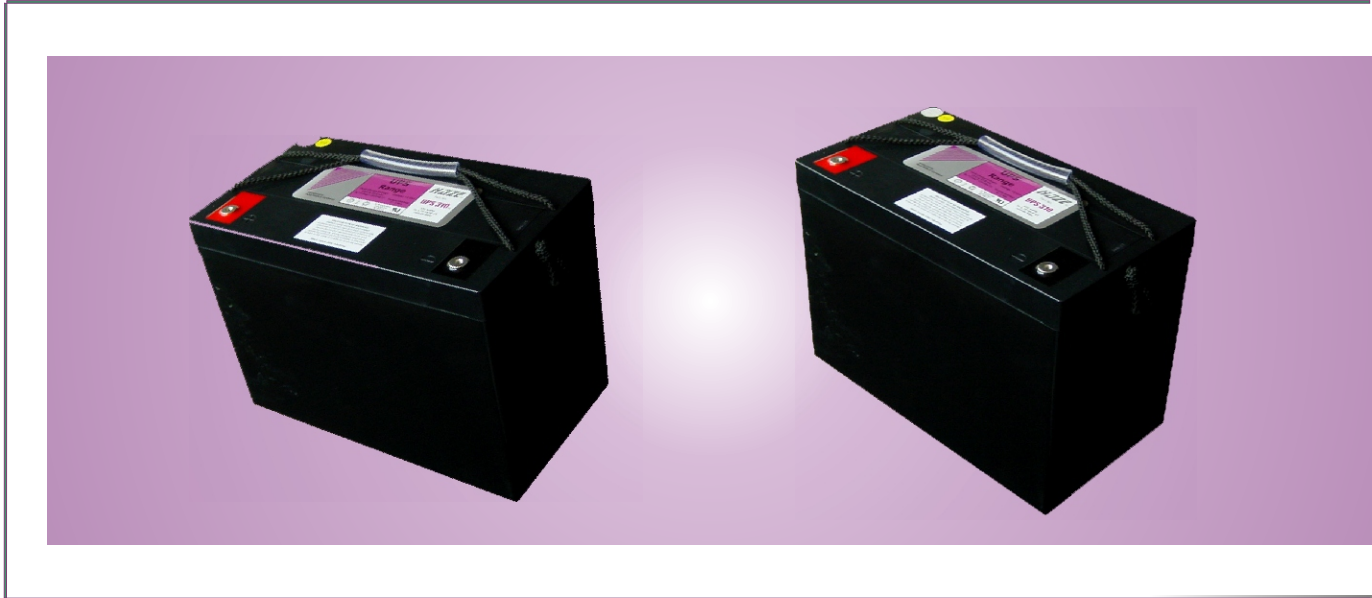

Haze Battery Company Ltd



**Model No. UPS 310** (12 Volts, 337 Watts Per Cell for 15 minutes to 1.67 vpc)

Valve Regulated Lead Acid Battery for UPS applications

**Innovative Features**

- ◆ Completely maintenance free, sealed construction eliminates the need for watering
- ◆ Fully tank formed plates
- ◆ Analytical Grade electrolyte
- ◆ Spill proof / leak proof
- ◆ Valve regulated Max internal pressure 2.5 psi
- ◆ Multi-position usage
- ◆ ABS Case & Cover Flame Retardant meets UL 94 VO requirements
- ◆ Low self discharge
- ◆ FAA and IATA approved as non-hazardous
- ◆ Designed to comply with IEC 896 Part 2, British Standard BS 6290 Part 4, Eurobat, DIN 43534
- ◆ UL Recognized, ISO 9001

**12 Volts - 337 Watts Per Cell for 15 minutes to 1.67 vpc**

Constant Power Discharge Ratings - Watts per cell @ 77°F (25°C)

Operating Time (minutes)	5	10	15	20	30	40	45	50	60	90
1.67 vpc	608.7	425.2	337.0	281.0	212.6	173.2	159.7	0.0	126.4	90.8

Website: [www.hazebattery.com/usa](http://www.hazebattery.com/usa)  
 E mail : [customerservice@hazebattery.com](mailto:customerservice@hazebattery.com)  
 Ph: 952-746-7528 Fax: 952-746-7527

AGM Range

Sealed Lead Acid 12 Volt Bloc

## Specifications

Nominal Voltage	12 Volts
Nominal Capacity at 77°F (25°C)	337 watts per cell at 15 minute rate to 1.67 vpc 98 Ah @ 20 hr rate to 1.75vpc

Dimensions	Total Height (Inc terminals)	8.19 inches	208 mm
		n/a	n/a
	Length	12.01 inches	305 mm
	Width	6.61 inches	168 mm
	Weight	70.72 lbs	32 Kg

## Characteristics

Internal Resistance	4 mOhms
Capacity correction for temperature Variations 77°F (25°C)	104°F (40°C) 102% 68°F (20°C) 100% 32°F (0°C) 85% 5°F (-15°C) 65%
Self Discharge 77°F (25 Deg C)	Capacity after 1 month storage 98% Capacity after 3 months storage 94% Capacity after 6 months storage 86%
Short Circuit Current 77°F (25 Deg C)	2900
Terminal	Standard 14mm Insert M6 thread
Charging (Float Voltage)	Float 2.27 - 2.30 vpc (59-77°F)



Haze Battery Company Ltd

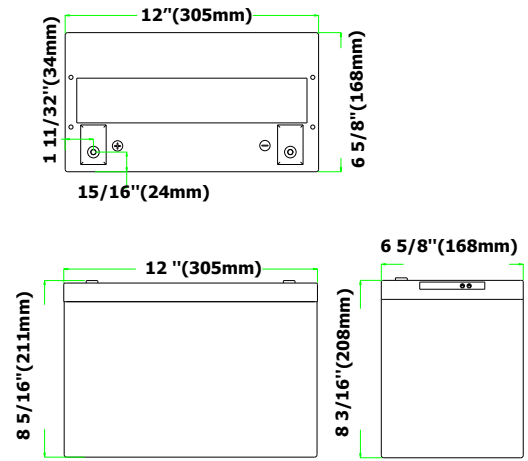

## Constant Current Discharge Ratings - Amperes @ 77°F (25°C)

Operating Time to End Voltage

End V per Cell	Minutes				Hours								
	5	15	30	45	1	2	3	4	5	8	10	12	20
1.85	235.4	157.6	102.7	77.9	61.4	34.2	24.0	18.6	15.2	10.2	8.4	7.2	4.6
1.80	286.2	172.1	108.9	80.6	63.4	35.2	24.5	18.9	15.5	10.4	8.6	7.4	4.8
1.75	304.9	179.4	111.0	82.4	64.7	35.8	24.9	19.2	15.8	10.6	8.8	7.5	4.9

## Constant Power Discharge Ratings - Watts Per Cell @ 77°F (25°C)

Operating Time to End Voltage (In minutes)

End V per Cell	5	10	15	20	30	40	45	60	90
1.75	552.7	403.4	323.5	271.7	206.4	169.0	156.6	124.4	88.9
1.70	579.7	414.8	331.8	276.9	209.5	171.1	157.6	125.4	89.8
1.65	608.7	425.2	337.0	281.0	212.6	173.2	159.7	126.4	90.8
1.60	639.8	435.5	342.2	285.2	214.7	174.2	160.7	127.5	91.5

## Specifications

Design Life	12 Years
Operating Temperature	-4 °F to 122 °F
Grid alloy	Calcium / Tin lead alloy
Plates	Flat Pasted
Separator	Absorbant Glass Mat
Active material	Very high purity lead
Charge Voltage	Float 2.25 - 2.30 VPC @77 °F Cycling 2.35 @77 °F Max. 2.4 VPC Max ripple 0.05C (A)
Electrolyte	Sulphuric acid Analytical grade purity
Venting Valve	EPDM Rubber 1.5 to 2 psi (10.5 - 14 KPa) release pressure. Resealing at 1 psi (7 KPa)
Torque setting	The recommended torque value for all types is 44-62 inch-pounds

## Terminal Details

Insert are made from brass with copper, nickel and silver plating giving excellent mechanical, electrical and corrosion resistant properties.  
Insert 14mm Dia M6 thread, epoxy sealed.

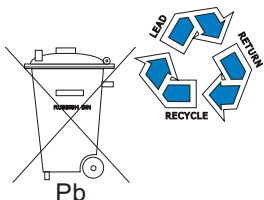

Haze Battery Company keenly encourages environmental awareness; PLEASE follow guidelines for the recycling /disposal of lead.

